

Development and Evaluation of Advanced Hydride Systems for Reversible Hydrogen Storage

Robert C. Bowman
Jet Propulsion Laboratory
California Institute of Technology
Pasadena, CA

– A Participant in the DOE Metal Hydride Center of Excellence –

May 23-24, 2005

This presentation does not contain any proprietary or confidential information

Timeline

- Project start date: FY05
- Project end date: FY09
- Percent complete: New Start

Budget

- Total Project Funding (Expected): \$1.78M
 - DOE Share: 100%
- DOE Funding for FY05: \$150K
- Funding expected in FY06: \$261K

Barriers

Weight and volume
Efficiency
Hydrogen capacity and reversibility
Degradation during cycling & from contamination

Targets

Gravimetric Capacity: >6 Wt.%
Min/Max Delivery Temp (°C): -30/85
Cycle Life @ >90% of Capacity: >1000 cycles

Partners

- Participant in Metal-Hydride Center of Excellence; collaborations with MHCoE partners on testing and characterization
- Member of sub-team on hydride-destabilized nanophase materials (with Caltech, HRL, Stanford U., U. Hawaii)
- Support system design and life-cycle issues for development of advanced hydride storage vessels (SNL, SRNL, GE, UNR)

Develop and demonstrate light-metal hydride systems that meets or exceeds the 2010/2015 DOE goals for on-board hydrogen storage

- (1) Validation of initial storage properties and reversibility in light element metal hydrides and assess their aging durability during extended cycling**
 - Nanophase, destabilized hydrides based upon LiH, MgH₂, LiBH₄ & TBD produced at HRL, Caltech, & other MHCoe partners.
 - Complex hydrides (e.g., amides/imides, borohydrides, & AlH₃-hydrides) provided by SNL, U. Hawaii, GE Global, BNL, and ORNL.
- (2) Support developing lighter weight and thermally efficient hydride storage vessels and experimentally demonstrating their compatibility with appropriate complex and destabilized nanophase hydrides.**

FY-05 Objectives:

- Determine reversibility of the destabilized LiH/Si system
- Evaluate behavior of destabilized MgH₂/Si & MgH₂/LiBH₄ systems
- Characterize phases & chemical bonding via MAS-NMR for Li amides/imides, AlH₃, & selected other hydrides provided by MHCoe partners

Perform Analysis and Characterization of Selected Hydrides:

- **Volumetric measurements on destabilized nanophase and complex metal hydrides.**
- **Magic Angle Spinning - Nuclear Magnetic Resonance (MAS-NMR) to assess the phase compositions and chemical bonding parameters.**
- **Examinations by XRD, EPR, neutron scattering and diffraction, etc. in collaboration with MHCoE partners.**

Prototype Hydride Beds Development and Life Testing:

- **Evaluate the performance and robustness using well-characterized experimental test-beds during many cycles of hydrogen absorption and desorption.**
- **Support development of more efficient hydride storage vessels to reduce storage system mass and demonstrate their compatibility with appropriate complex and destabilized nanophase hydrides.**
- **Support system design and analyses using methods established at JPL for sorption cryocooler hydride compressor beds.**



- Sub-team coordination
- Hydride destabilization strategies
- Nanoparticle synthesis
- Hydrogen cycling: test and characterization
- Nanoparticle synthesis (gas condensation)
- Materials Characterization (TEM, XRD)
- Nanostructured catalyst development
- New synthesis routes
- *In situ*, real-time synchrotron XRD of H-induced phase changes
- Nanoparticle synthesis
- Solid state reaction kinetics
- Thin film reactions
- Materials development (performance / aging properties)
- Reaction kinetics and metal atom motion
- Phase formation & compositions via NMR
- Concept testbeds

Other partners in MHCoE will also contribute in areas of nanostructure synthesis, diagnostics and modeling/simulation

LiH-Si was First System that Stabilized the Dehydrogenated State to Increase P_{equilibrium}

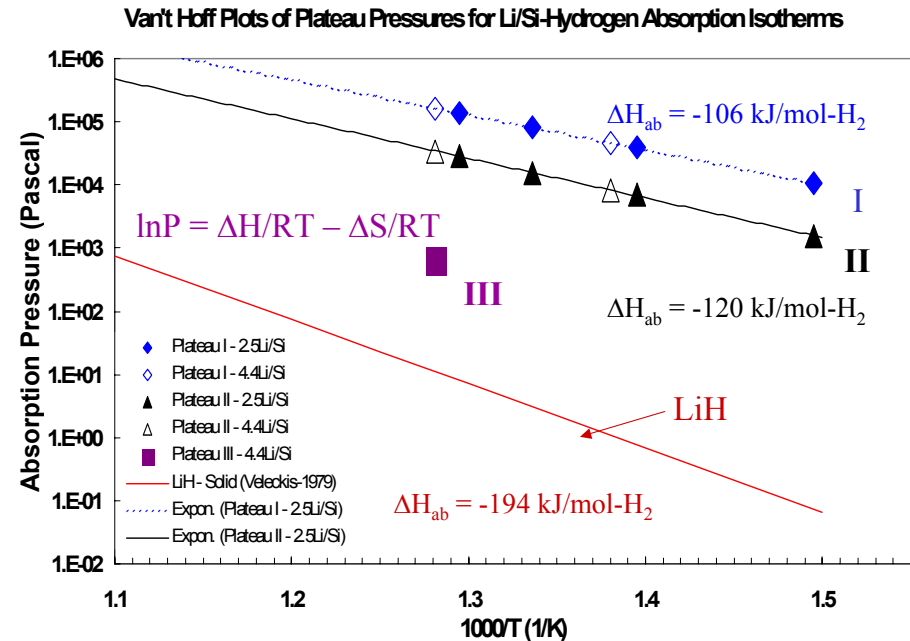
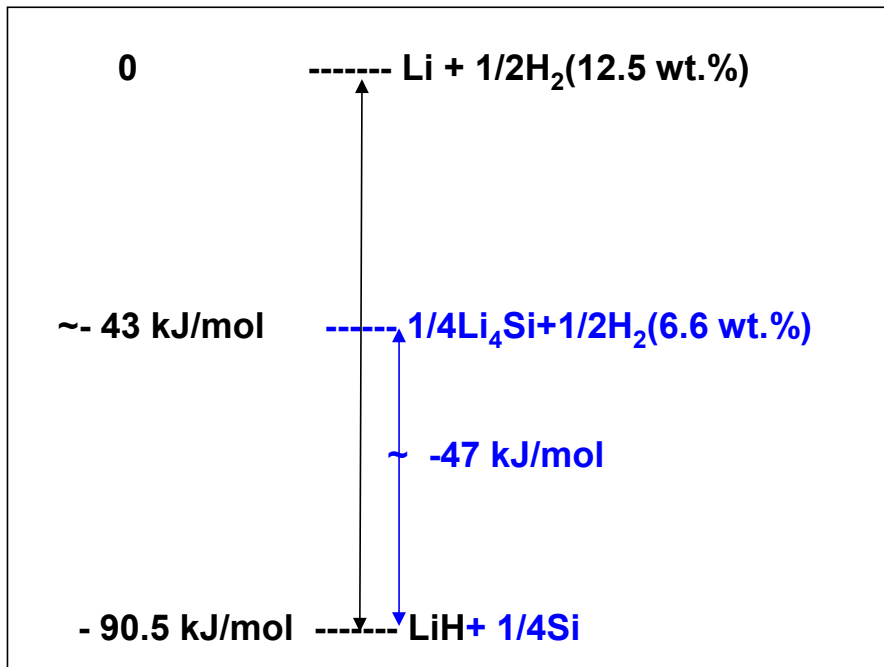

LiH/Si Pressures $> 10^3$ for LiH

J. Vajo, et al., J. Phys. Chem. B108, 13977 (2004)

Reversible Capacity and Pressure Effected by Multiple Li_xSi_y Phases

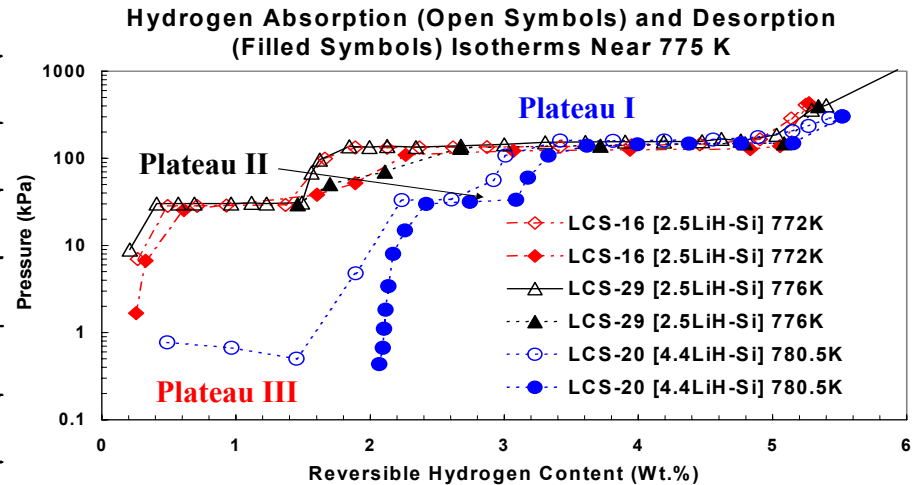
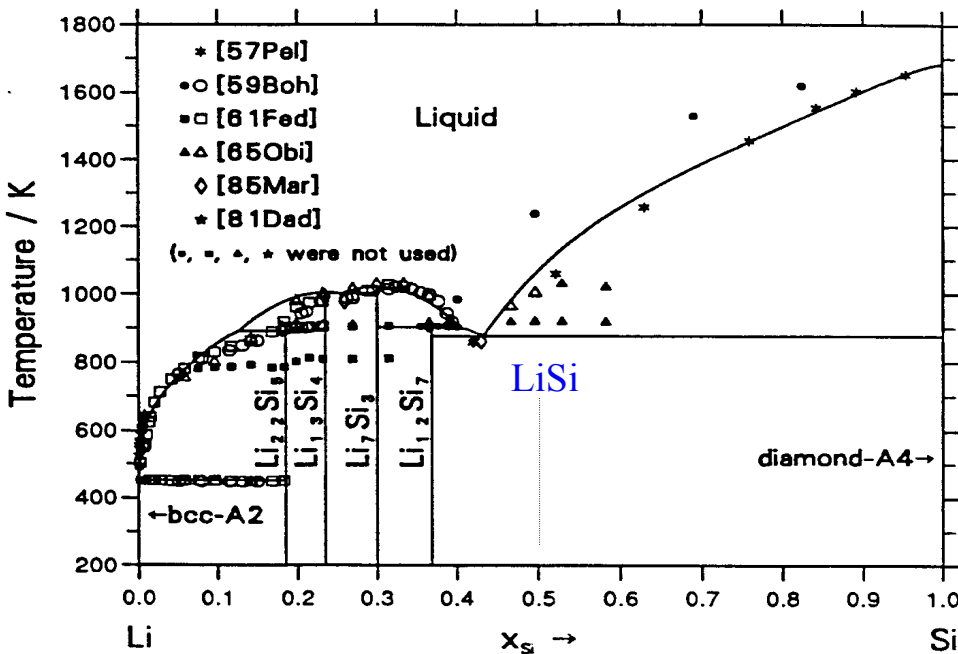

Li-Si Phase Diagram – Braga, et al. (1995) & Stearns, et al., (2003)

R. C. Bowman, Jr., et al., MRS Proc. Vol. **837** (2005) N3.6.1

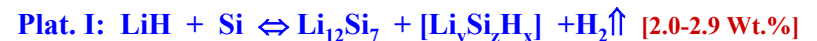

MAS-NMR spectra were used to identify phases produced

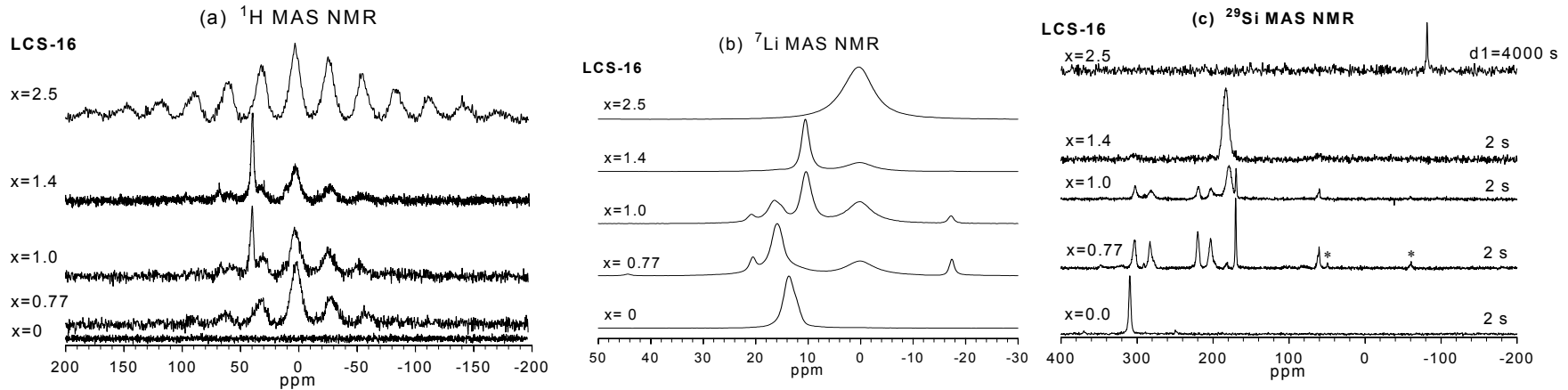

- XRD & NMR studies show a new $\text{Li}_y\text{Si}_z\text{H}_x$ phase as well as expected Li_ySi_z and LiH phases in different plateau & transition regions.
- Raman indicates presence of crystalline Si and not a-SiH_x phases
- Samples sent to NIST for Inelastic Neutron Scattering of vibration modes & Prompt Gamma-ray Activation Analysis of total H-contents also indicate a new ternary phase can form

R. C. Bowman, Jr., et al., MRS Proc. Vol. **837** (2005) N3.6.1

Identify intrinsic degradation rates & products that occur for a few most promising (e.g., > 5 wt.%) light-element hydrides during extended cycling (i.e., > 1000 cycles) of samples in 10-20 grams size range.

- Intrinsic degradation of the hydride phases will be monitored during cycling on the JPL life-cycle test facilities.
- Formation of contaminant species (i.e., methane, ammonia, etc.) released by the hydride decomposition or produced from interactions sorbent bed components
- Characterize impact on the hydrogen storage capacity, reversibility, and reaction kinetics using Sieverts-type volumetric measurements combined with quadrupole mass spectrometry (QMS)



JPL Hydride activation and cycling test station

JPL studies will primarily focus on intrinsic degradation processes & thus will complement the assessment of effects from gaseous impurities and cycling being performed at U. Nevada - Reno

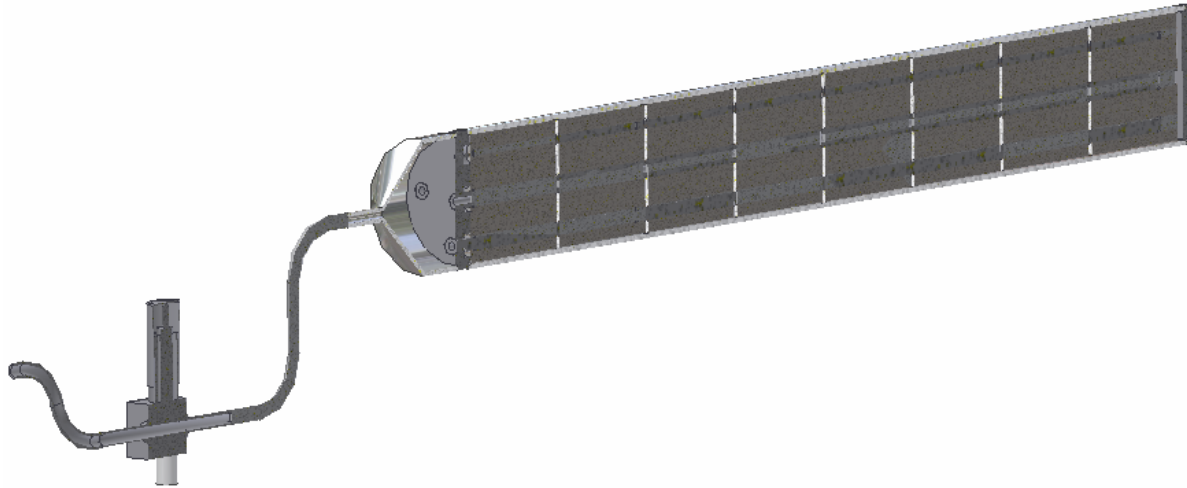
Design and analyze performance of practical complex hydride storage beds.

- Reduce the system mass with improved mass and thermal efficient hydride designs.
- Provide efficient thermal management during hydrogen filling and discharging operations in compliance with the DOE performance requirements.
- JPL used this approach to develop metal hydride compressor beds for its space flight sorption cryocoolers that exceeded specifications and performance requirements.
- JPL will adapt its bed design modeling and analysis software for light element hydrides.
- These predictive and simulation models would use appropriate thermophysical parameters as provided by SNL, the MHCoe partners, and other sources.

Evaluate prototypes of complex hydride storage beds during laboratory tests.

- **Issues:** hydrogen storage characteristics, particle size range and distribution, heat and mass transfer parameters, minimal weights, mechanical strength, and strict attention to all aspects related to safety.
- **Optimize pathways for cost effective and reliable fabrication.**
- **Approach used at JPL to produce metal hydride compressor beds for its space flight sorption cryocoolers that met/exceeded performance requirements.**
- **Look for intrinsic degradation or formation of contaminants within the hydride bed or from interactions with its structural components.**

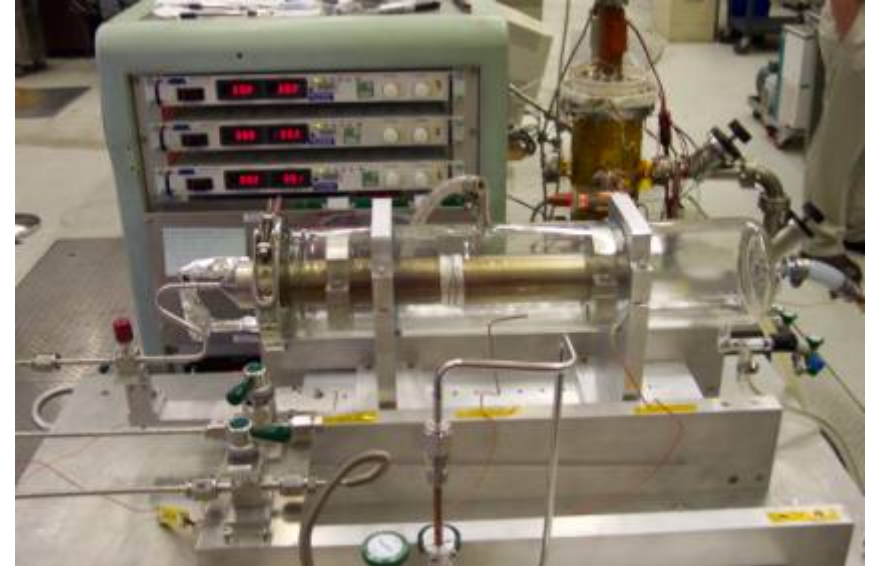

Planck Cooler Flight Low Pressure Storage Bed after activation and hydrogen charging

In Phase II (yrs 3-5), assess developmental versions of beds filled with the most promising candidate hydrides to validate their robustness and durability during cycling in prototypes.

Operation with a Schematic Hydride Storage Bed with a Gas Gap Heat Switch

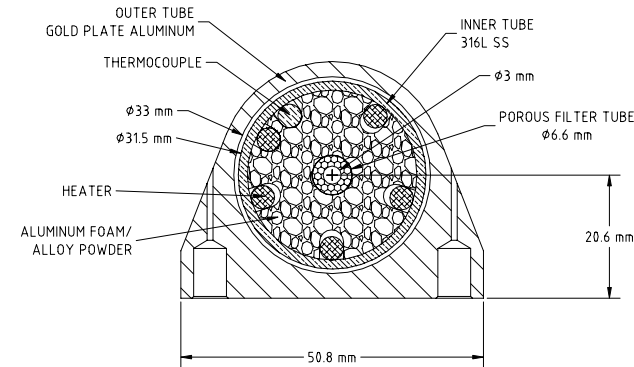
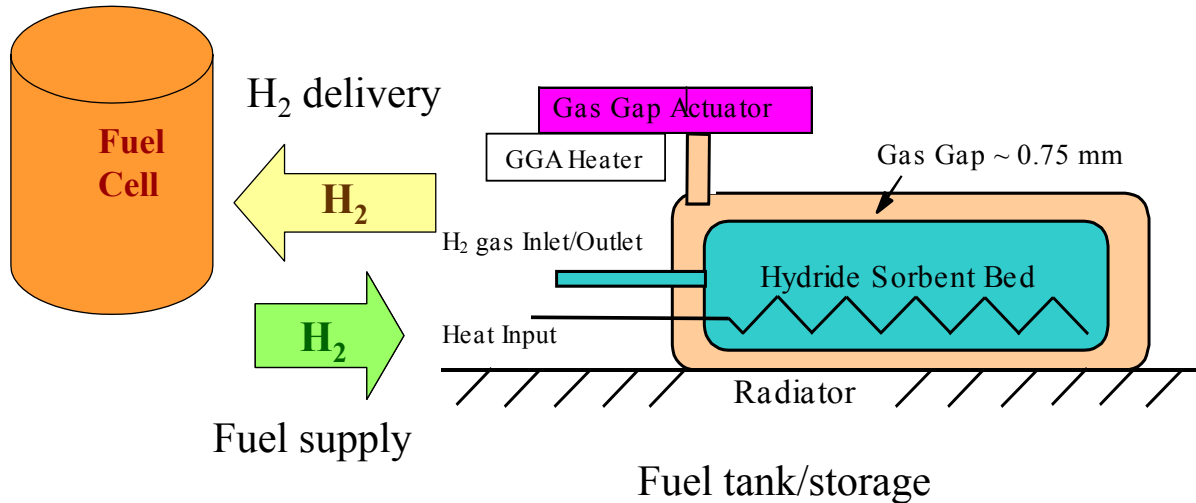

Cross section of hydride storage Bed

- Off- GGHS = Vacuum (< 1.0 Pa) during H_2 delivery (Desorbing from Bed)
- On- GGHS = Pressurized (> 1000 Pa) during H_2 absorption from Fuel supply

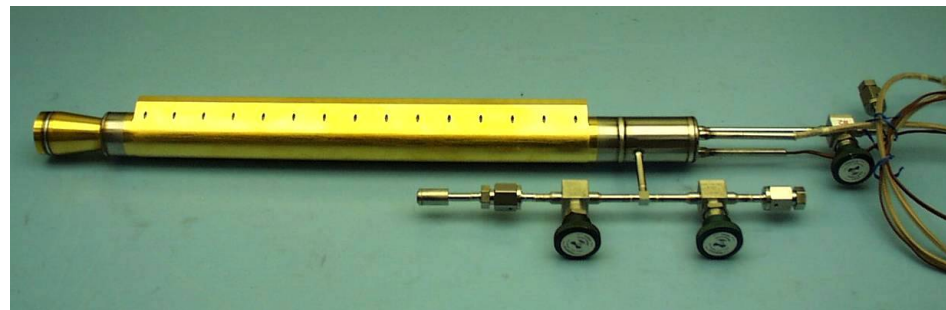

Improve understanding of catalysts, dopants, and processing on amides/imides, alanates, borohydrides, and other novel light element hydrides.

- Use solid-state NMR methods to characterize diffusion parameters on samples provided by various MHCoe partners.
- Measurements @ Caltech Solid State NMR Facility [Dr. Sonjong Hwang]
- Provide novel insights on the phase compositions and local chemical bonding parameters for crystalline and highly disordered (i.e., amorphous) phases at various stages of reactions.
- Being done in collaboration with MHCoe partners (i.e., Caltech, NIST, SNL, etc.) utilizing their specialized instrumentation (i.e., XRD, neutron scattering, Raman, etc.) and expertise.
- NMR results will test and complement theoretical modeling of mechanisms for nanophase formation and transitions

Provide unique atomistic information on mechanisms for the reversible formation and decomposition of hydride phases that differ from processes operating in conventional interstitial metal hydrides.

Representative Spectra for AlH_3 [BNL] and $\text{LiNH}_2/\text{MgH}_2/\text{Mg}(\text{NH}_2)_2$ [SNL]

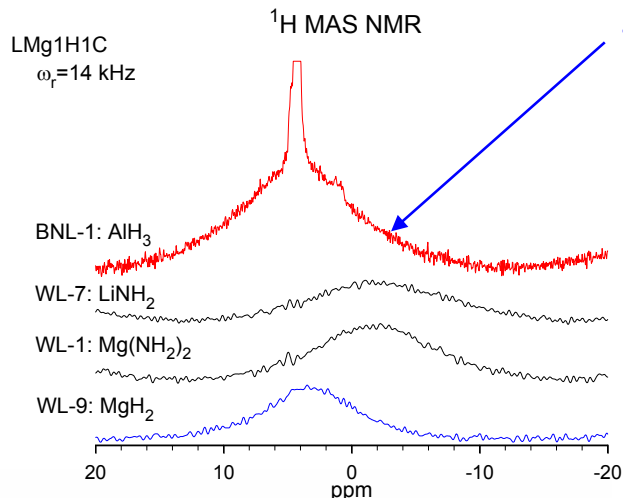

^1H & ^{27}Al Peaks identify phase, local structure, & bonding

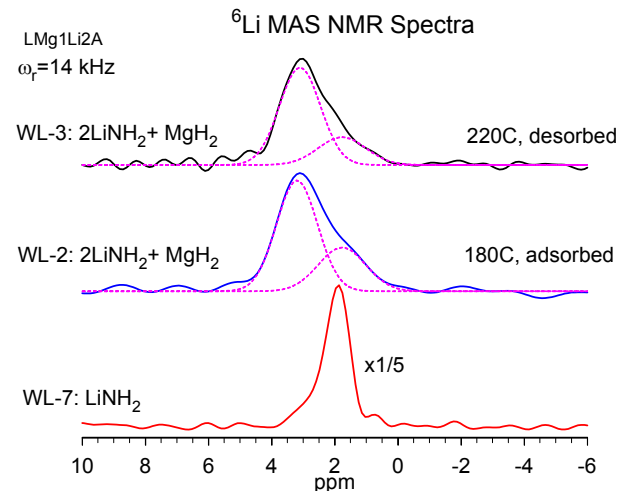

Al Metal Peak (~1637 ppm)

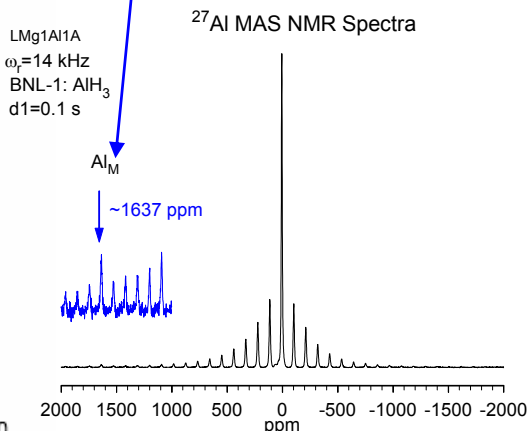
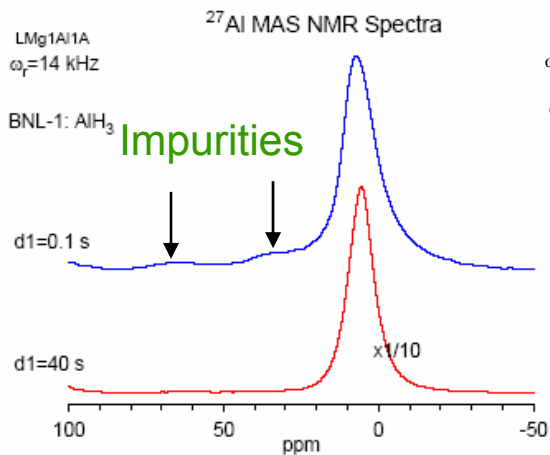

Sub-peaks in ^6Li spectra to track changes in phase composition with H-content—compare to isotherms and modeling reaction processes.

Main AlH_3 Peak @ 5.8 ppm

Note: These are preliminary results currently being analyzed with additional experiments in progress

Project Plans & Schedule for Technical Effort by JPL (Go/No-Go Points Shown by Solid Red Circles)

TASKS	FY-05				FY-06				FY-07				FY-08				FY-09			
	1	2	3	4	1	2	3	4	1	2	3	4	1	2	3	4	1	2	3	4
1. Destabilized Hydride Systems																				
Life-cycling of LiH-Si only if capacity > 5 wt%				●																
Continue Reversibility in MgH ₂ -Si and LiH-Si						●														
Reversibility studies on model LiH and MgH ₂ -Si systems																				
Initial degradation study on first destabilized nanophase systems																				
Initiate life cycle testing on best destabilized nanophase candidates																				
Life cycle testing on best destabilized nanophase candidates																				
Initiate life cycling of optimized nanophase hydride																				
2. Degradation Studies of Light-Element Hydrides																				
Adapt JPL test facilities and screen TBD candidate samples																				
Evaluate selected materials as provided by MHCoe partners																				
Perform accelerated life-cycling on selected materials from MHCoe partners																				
3. Prototype Hydride Storage Bed Design & Testing																				
Conceptual design for a prototype complex hydride sorbent bed																				
Refined design recommendations for 1-Kg H ₂ capacity prototype bed																				
Life-cycling testing of developmental prototype beds																				
4. NMR Studies of Advanced Complex Hydrides																				
1 st phase NMR studies on AlH ₃ , Mg-Si-H, LiNH _x /MgH _x samples																				
NMR studies on alanates, borohydrides, amides, etc. from MHCoe team																				

Specific tasks to be performed by JPL in order of priority:

1. Characterization and Testing of Destabilized Hydride Systems
2. Evaluations of Degradation Behavior in Light Element Hydrides
3. Prototype Hydride Storage Bed Analysis, Design and Testing
4. NMR Evaluations of Advanced Complex Hydrides

FY-05 Milestones	Months from Program Start
Complete phase formation & reversibility studies on model LiH-Si, LiH-Ge and MgH₂-Si systems (Task 1)	9
Adapt JPL cycling test facilities and start screenings of Li/Mg Amide, MgH₂/LiBH₄ or TBD samples (Task 2)	9
Perform initial MAS-NMR characterization of phase composition of AlH₃ and Li/Mg Amide samples (Task 4)	6

Activities & Milestones	Task Area
Complete degradation study of first destabilized nanophase systems (i.e., MgH_2/Si & $MgH_2/LiBH_4$)	Task 1
Evaluate degradation behavior during cycling of first selected MHCoE materials (i.e., Li/Mg amides, Al-based hydride, TBD)	Task 2
Develop a conceptual design of prototype hydride sorbent bed that improves capacity & thermal efficiency over current configurations	Task 3
Perform first generation thermal modeling & system analyses on prototype bed designs using a candidate hydride in the design	Task 3
Complete 1 st phase NMR studies on $LiH-AlH_3$ & Li/Mg amides	Task 4
Perform survey MAS-NMR studies on promising candidates (i.e., alanates, borohydrides, amides, etc.) as provided by MHCoE team	Task 4

Go/No-Go Points:

- Selections for degradation and NMR studies will be based upon both assessment of observed performance during survey testing and candidates' potential for meeting DOE 2010/2015 targets.
- Excessive degradation or decomposition from any nanophase or advanced complex hydride during cycling test stage, further evaluations will be discontinued and another candidate investigated.